

# R2900G

Underground  
Mining Loader



---

## Engine

Engine Model	Cat® C15 ACERT™	
Gross Power – SAE J1995	321/333 kW	430/447 hp

---

## Operating Specifications

Nominal Payload Capacity	17 200 kg	37,926 lb
Gross Machine Operating Weight	67 409 kg	148,611 lb

---

## Bucket Capacities

Bucket Capacity – Std.	7.2 m <sup>3</sup>	9.4 yd <sup>3</sup>
------------------------	--------------------	---------------------

# R2900G Underground Mining Loader

*Engineered for performance. Designed for comfort. Built to last.*

---

## Power Train – Engine

The Cat C15<sup>®</sup> engine with ACERT™ Technology delivers the power and reliability necessary to perform in the most demanding underground mining applications. Designed for efficient operation, excellent fuel efficiency, lower emissions, reduced engine noise and lower operating costs. **pg. 4**

---

## Power Train – Transmission

The Cat four-speed planetary power shift transmission features heavy duty components to handle the toughest jobs. Electronic controls allow smooth shifting for greater productivity, durability and longer component life. **pg. 5**

---

## Hydraulics

Powerful Cat hydraulics deliver excellent digging and lifting forces to move materials quickly. High volume pumps and large cylinders provide quick, powerful response and fast cycle times. Pilot operated joysticks provide low effort operation and smooth control. **pg. 6**

---

## Serviceability

The R2900G is designed for quick and easy servicing. Simplified service and maintenance features reduce downtime, allowing the machine to spend less time being serviced and more time being productive. **pg. 11**

---

## Customer Support

Caterpillar<sup>®</sup> dealers provide unmatched product support, anywhere in the world. With industry-best parts availability and a wide range of maintenance and service options, Cat dealers have what it takes to keep your mining machines productive. **pg. 12**

---

## Safety

Caterpillar sets the standard when it comes to safety in the design and manufacturing of heavy equipment for the mining industry. Safety is not an after thought at Caterpillar, but an integral part of all machine and systems designs. **pg. 13**

### *Performance and Agility.*

*Compact design, high engine power, higher torque rise, stronger components and excellent maneuverability ensures the R2900G is a solid performer.*

### *Unmatched Operator Comfort.*

*World class operator station fitted with revolutionary electronics and hydraulic controls for low effort operation and increased productivity.*



---

### Structures

Structural components are the backbone of the R2900G durability. The heavy duty loader frame is designed and built to absorb twisting, impact and high loading forces for maximum durability and reliability. Z-bar linkage generates powerful breakout forces and optimum loading angle. **pg. 7**

---

### Operator Station

The ergonomic cab is designed for operator comfort and ease of operation to allow the operator to focus on production. Controls and gauges are positioned within easy reach for optimum efficiency and superior control all shift long. **pg. 8**

---

### Buckets

Cat underground loader buckets are designed for optimal loadability and structural durability in tough mining conditions. A ranges of sizes and configurations are available to match material conditions and maximize productivity. **pg. 10**



## Power Train – Engine

*The Cat® C15 engine with ACERT™ Technology delivers the power and reliability necessary to perform in the most demanding underground mining applications.*

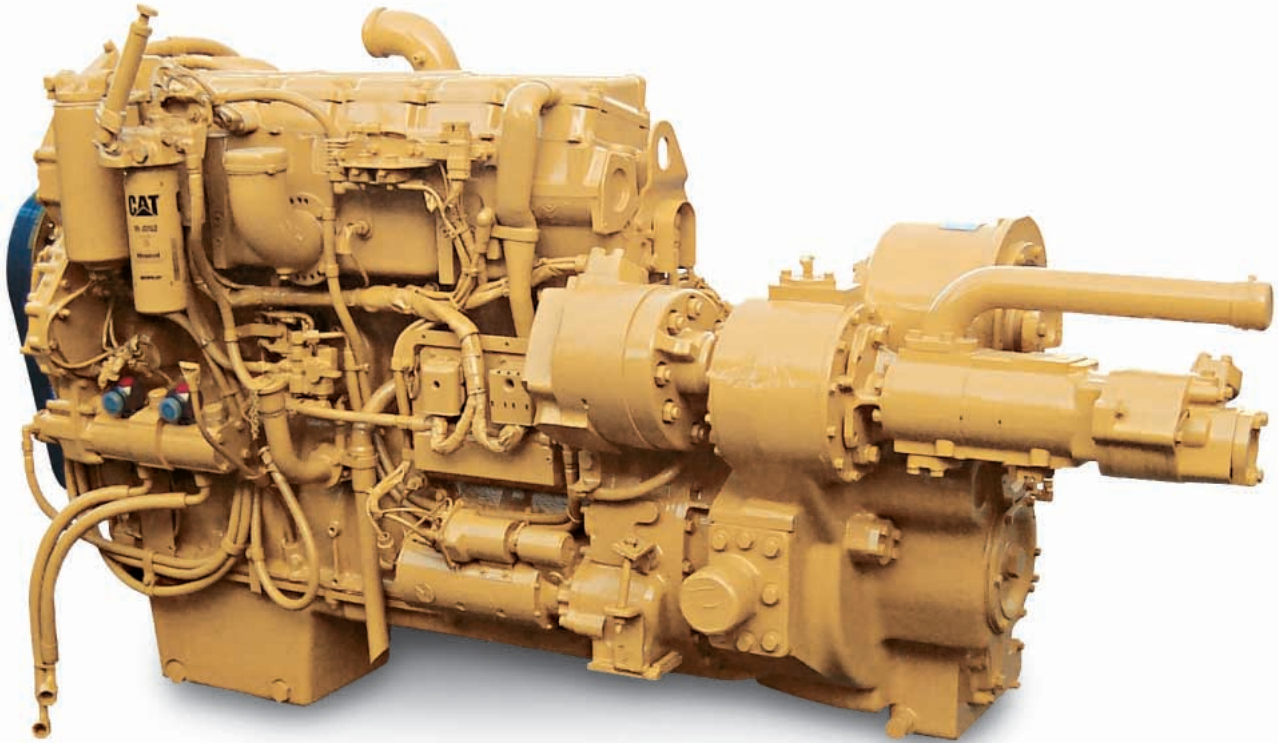

**Cat C15 Engine with ACERT™ Technology.** The Cat C15 engine with ACERT™ Technology is U.S. EPA Tier 3 and EU Stage III compliant. It features efficient fuel management for quick response, high productivity and exceptional service life. A new, sculptured cylinder block provides greater strength and lighter weight.

**High Torque Rise.** Provides unequalled lugging force while digging, tramming and traversing steep grades. Torque rise effectively matches transmission shift points for maximum efficiency and fast cycle times.

**Radiator.** Modular radiator with swing-out grill provides easy access for cleaning or repair. Built in sight gauge allows for quick, safe coolant level checks.

**Pistons.** Oil cooled pistons increase heat dissipation and promote longer piston life.

**ADEM™ IV System.** Controls the fuel injector solenoids to monitor fuel injection. This system provides automatic altitude compensation, air filter restriction indication and it will not allow the engine to fire until it has oil pressure, acting as cold start protection and a form of pre-lube.

**Turbocharged and Aftercooled.** Air-to-air aftercooling provides improved fuel economy by packing cooler, denser air into cylinders for more complete combustion of fuel and lower emissions. The turbocharger enhances performance and efficiency.

**Mechanically Actuated, Electronic Unit Injection (MEUI).** Proven high-pressure, direct injection fuel system electronically monitors operator demands and sensor inputs to optimize engine performance.

**Cylinder Liners.** Full-length water-cooled cylinder liners provide maximum heat transfer.

**Crankshaft.** The crankshaft is forged and induction hardened for long-term durability.

## Power Train – Transmission

*Designed for durability, the Cat power shift transmission delivers smooth, responsive performance and reliability in tough conditions.*

### Power Shift Transmission.

The Cat four-speed planetary power shift transmission is matched with the C15 engine with ACERT™ Technology to deliver constant power over a wide range of operating speeds.

- Hydraulic modulation cushions the shift and reduces stress on components.
- High contact pump drive and output transfer gears are used to reduce sound levels.
- Pump drive and output transfer use high contact gear ratios to reduce sound levels.
- Perimeter mounted, large diameter clutch packs control inertia for smooth shifting and increased component life.

**Robust Design.** Designed for rugged underground mining conditions, the proven planetary power shift transmission is built for long life between overhauls.

**Electronic Controls.** Electronic controls allow smooth, on-the-go shifting for greater productivity.

**Torque Converter.** High capacity torque converter delivers more power to the wheels for superior power train efficiency.

### Electronic Autoshift Transmission.

The electronic autoshift transmission increases operator efficiencies and optimizes machine performance. The operator can choose between manual or auto shift modes.

**Transmission Neutralizer.** Using the left brake pedal, the operator can engage the service brakes and neutralize the transmission, maintaining high engine rpm for full hydraulic flow, enhancing digging and loading functions.

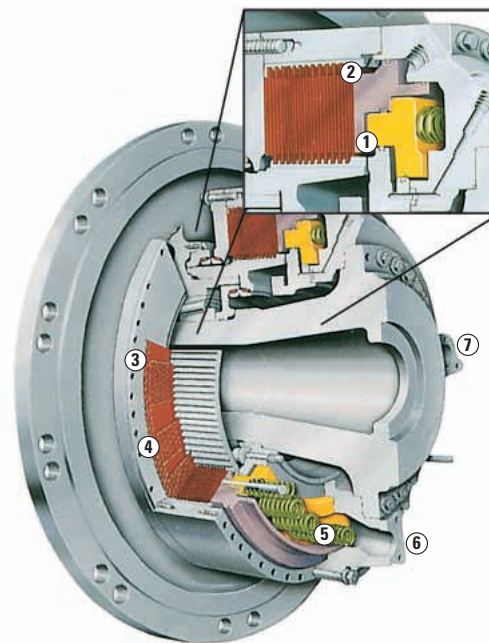

- 1 Parking/Secondary Piston
- 2 Service/Retarding Piston
- 3 Friction Discs
- 4 Steel Plates
- 5 Actuating Springs
- 6 Cooling Oil In
- 7 Cooling Oil Out

**Final Drives.** Cat final drives work as a system with the planetary power shift transmission to deliver maximum power to the ground. Built to withstand the forces of high torque and impact loads, final drives provide high torque multiplication to further reduce drive train stress.

**Axles.** Heavy duty axles are built rugged for long-life in the most demanding environments.

**Oscillating Rear Axle.** Oscillating rear axle ensures four-wheel ground contact for maximum traction and stability at all times.

**Duo-Cone™ Seals.** Duo-Cone™ seals between the axle spindle and housings keep lubrication in and contaminants out.

**Brakes.** Fully enclosed oil immersed disc brakes incorporate independent service and parking brake pistons. Hydraulic actuated independent circuits provide improved performance and reliability.

**Cat Electronic Technician.** Cat ET service tool provides service technicians with easy access to stored diagnostic data through the Cat Data Link to simplify problem diagnosis and increase availability.

## Hydraulics

*Cat hydraulics deliver the power and control to keep material moving.*



**Hydraulic System.** Powerful Cat hydraulics deliver exceptional digging and lifting forces for fast cycle times.

**Lift and Tilt System.** High hydraulic flow rates provide fast hydraulic cylinder response and powerful lift forces. Large-bore lift and tilt cylinder delivers exceptional strength, performance and durability.

**Pilot Controls.** Low effort, pilot operated joystick implement control with simultaneous lift and tilt functions optimizes operating efficiency.

**Optional Ride Control.** The optional ride control system uses a nitrogen filled oil accumulator in the hydraulic lift circuit to act as a shock absorber for the bucket and lift arms. The lift arm and bucket response to movement is dampened over rough ground, reducing fore and aft pitch, improving cycle times and load retention. A smoother, more comfortable ride gives operators the confidence to travel at speeds above 5 km/h (3 mph) during load and carry operations.

**Cat Hydraulic Hose.** Field proven Cat high pressure XT™ hydraulic hoses are exceptionally strong and flexible for maximum system reliability and long life in the most demanding conditions. Reusable couplings with O-ring face seals provide superior, leak free performance and prolong hose assembly life.

## Structures

*Designed for maximum strength and durability in the harshest operating environments.*

**Frame Design.** The frame features robust structural components for outstanding durability in the toughest loading conditions. Caterpillar integrates advanced processes in the design and manufacture of Cat frames and structures. Computer modeling and Finite Element Analysis (FEA) are used extensively throughout design.

**Steel Frame.** Strong steel frame structures are designed to resist twisting forces, torsional shock and stresses generated during the loading cycle while protecting drive line and hydraulic system components.

**Lift Arms.** Solid steel lift arms absorb high stresses generated during loading without sacrificing strength or durability. The linkage design offers excellent reach and dump clearance for better productivity. Lift arm support pins prevent lowering the lift arms during service and maintenance.

**Loader Tower.** The four plate loader tower provides a solid mount for lift arms, lift cylinders and Z-bar tilt lever. The loader frame is designed and built to absorb twisting, impact and high loading forces.

**Cast-Steel Cross Tube.** The cast steel cross tube provides excellent resistance to torsion and impact loads, keeping pin bores aligned and extending component service life.

**Z-Bar Loader Linkage.** Proven Z-Bar loader linkage geometry generates powerful breakout force and an increased rack back angle for better bucket loading and material retention.

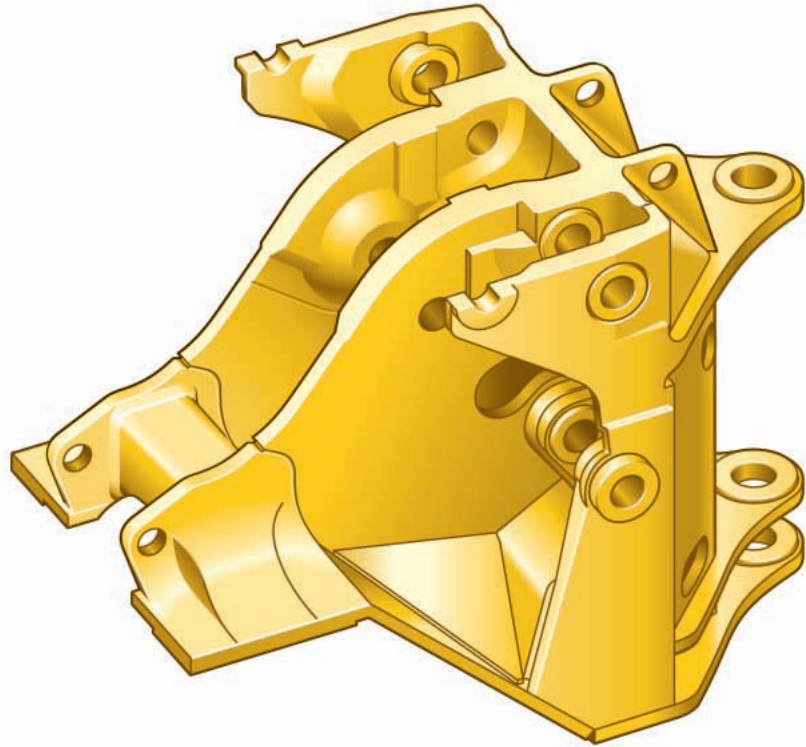

**Sealed Pins.** Sealed colleted pins are fitted to all bucket and lift arm hinge points for longer pin and bushing life. This reduces maintenance costs and extends service intervals. The sealed joints retain lubrication and prevent contaminant entry.

**Hitch.** Spread hitch design widens the distance between upper and lower hitch plates to distribute forces and increase bearing life. Thicker hitch plates reduce deflection. The wide opening provides easy service access. Upper and lower hitch pins pivot on roller bearings to distribute horizontal and vertical loads over a greater surface area. Shim adjusted preload reduces maintenance time. An on-board steering frame lock pin is fitted to prevent articulation during maintenance and service.

## Operator Station

*Setting a new industry standard for comfort and efficiency.*



**Ergonomic Layout.** The operator station is ergonomically designed for total machine control in a comfortable, productive and safe environment. All controls, levers switches and gauges are positioned to maximize productivity and minimize operator fatigue.

**Pilot Controls.** Low-effort pilot operated joystick controls integrate steering, transmission and implement functions for smoother, faster cycles with less operator fatigue.

**Electronic Autoshift.** Allows the operator to choose automatic or manual shifting. In auto mode, the operator uses a dash mounted switch to select the highest gear they wish the machine to shift to. In this mode, the transmission shifts at factory preset shift points so that each shift occurs at optimum torque and ground speed for maximum machine performance.

**Dual-Pedal Braking.** Dual brake pedals function as a brake and a transmission neutralizer so the operator can maintain high engine rpm for full hydraulic flow and fast cycle times.

**Protective Structure.** Integral to the cab and frame, the Rollover Protective Structure (ROPS) is resiliently mounted to the frame to isolate the operator from vibration for a more comfortable ride.

**Suspension Seat.** Suspension seat provides optimal driving position and enhances operator comfort, all shift long.





**STIC™ Steering Control.** STIC™ combines directional selection, gear selection and steering into a single lever for maximum responsiveness. Simple side-to-side motion turns machine right or left. Transmission shifting (forward/neutral/reverse) is controlled using a three position rocker switch. The thumb operated upshift and downshift button controls manual shifting.

**Optional Enclosed Cab.** Optional sound-suppressed ROPS cab provides a quiet, secure working environment. Large window openings offer excellent visibility in all directions. Enclosed design provides fresh, pressurized, temperature-controlled air circulation with air-conditioned comfort and a more comfortable working environment.

**Optional Ride Control.** The system uses a nitrogen filled oil accumulator in the hydraulic lift circuit to act as a shock absorber for the bucket and lift arms. The lift arm bucket response to movement is dampened over rough ground, reducing fore and aft pitch, improving cycle times and load retention. A smoother, more comfortable ride gives operators the confidence to travel at higher speeds during load and carry applications.

**Monitoring System.** Caterpillar Electronic Monitoring System (CEMS) continuously provides critical machine data to keep the machine performing at top production levels. A warning system alerts the operator of immediate or impending problems with engine oil pressure, parking brake engagement, brake oil pressure, electrical system, low fuel, hydraulic oil temperature, coolant level/temperature, transmission oil temperature and impending brake application.

• **Message Center.** Three-category warning system alerts operator of abnormal machine health conditions.

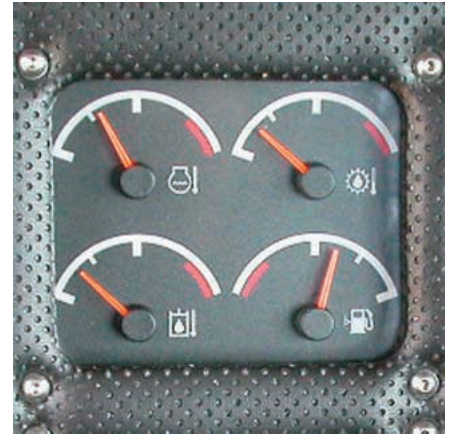

• **Gauge Cluster.** Maintains a constant display of vital machine functions, including: engine coolant temperature, brake oil temperature, air system pressure and fuel level.



• **Speedometer/Tachometer Module.** Monitors three systems: engine speed, ground speed and gear indicator.

## Buckets

*Cat buckets provide the flexibility to match the machine to the material and conditions.*



**Bucket Capacities.** Buckets are available in a range of sizes and capacities to suit most material types and densities.

**Wear Packages.** Weld-on wear plates in high wear areas are standard. Additional wear packages are available, including sacrificial wear strips and Cat heel shrouds, protect the edges from damage for longer bucket life and reduce the need for costly bucket rebuilds.

**Cutting Edges.** Cat half arrow and cast half arrow cutting edges extend bucket life in high wear applications.

**Buckets.** Aggressive Cat bucket designs deliver unmatched productivity in the most demanding applications. Underground mining buckets are designed for optimal loadability and structural reliability to increase productivity and help lower your cost-per-ton.



**Bucket Selection.** Cat underground loader buckets are available in standard and penetration configurations to meet a range of loading, hauling and dumping conditions.

## Serviceability

*Less time spent on maintenance means more time being productive.*

**Service Access.** Easy access to daily service points simplifies servicing and reduces time spent on regular maintenance procedures.

**Ground-Level Access.** Allows convenient servicing to all tanks, air filters, lubrication points and compartment drains.

**Air Filters.** Radial seal air filters are easy to change, reducing time required for air filter maintenance.

**Sight Gauges.** Makes fluid levels checks quick and easy.

**Diagnostics.** Cat Electronic Technician (Cat ET) Service Tool enables quick electronic diagnosis of machine performance and key diagnostic data for effective maintenance and repairs.

**Sealed Electrical Connectors.** Electrical connectors are sealed to lock out dust and moisture. Harnesses are externally sealed with flame resistant sleeves/covers for protection. Wires are color and number coded for easy diagnosis and repair.

**Scheduled Oil Sampling.** S•O•S<sup>SM</sup> sampling valves speed sampling and analysis reliability.



## Customer Support

*Caterpillar dealers have what it takes to keep mining underground equipment productive.*



### **Commitment Makes the Difference.**

Cat dealers offer a wide range of solutions, services and products that help you lower costs, enhance productivity and manage your operation more efficiently. Support goes far beyond parts and service. From the time you select a piece of Cat equipment until the day you rebuild, trade or sell it, the support you get from your Cat dealer makes the difference that counts.

**Dealer Capability.** Cat dealers will provide the level of support you need, on a global scale. Dealer expert technicians have the knowledge, experience, training and tooling necessary to handle your repair and maintenance needs, when and where you need them.

**Product Support.** Cat dealers believe superior products deserve superior support. When Cat products reach the field, they are supported by a worldwide network of parts distribution facilities, dealer service centers, and technical training facilities to keep your equipment up and running. Cat customers rely on prompt, dependable parts availability and expertise through our global dealer network, ready to meet your needs 24/7.

**Service Support.** Every piece of Cat equipment is designed and built to provide maximum productivity and operating economy throughout its working life. Cat dealers offer a wide range of service plans that will maximize uptime and return on your investment, including:

- Preventive Maintenance Programs
- Diagnostic Programs, such as Scheduled Oil Sampling and Technical Analysis
- Rebuild and Reman Options
- Customer Support Agreements

**Technology Products.** Cat dealers offer a range of advanced technology products designed to improve fleet efficiency, increase productivity, and lower costs.

**www.cat.com.** For more complete information on Cat products, dealer services, and industry solutions, visit us on the web at [www.cat.com](http://www.cat.com).

**Operation.** With today's complex products, equipment operators must have a thorough understanding of machine systems and operating techniques to maximize efficiency and profitability. Your Cat dealer can arrange training programs to help operator's improve productivity, decrease downtime, reduce operating costs, enhance safety, and improve return on the investment you make in Cat products.

## Safety

*Caterpillar mining machines and systems are designed with safety as their first priority.*

**Product Safety.** Caterpillar has been and continues to be proactive in developing mining machines that meet or exceed safety standards. Safety is an integral part of all machine and systems designs.

**Engine Shut Off Switch.** A secondary engine shutoff switch is located at ground level.

**Integral ROPS Cab.** Integral to the cab and frame, the ROPS is resiliently mounted to the frame to isolate the operator from vibration for a more comfortable ride.

**Brake Systems.** Four corner oil-cooled braking system provides excellent control. The service brake system is actuated by modulated hydraulic pressure, while the parking break function is spring applied and hydraulic released. This system assures braking in the event of loss of hydraulic failure.

### Standard Safety Features.

- Anti-skid upper deck surfaces
- Lower cab light
- Ground level compartment sight glasses
- Increased visibility
- 3-point access to cab and machine
- Push out safety glass
- Suspension seat
- Inertia reel retractable seat belt
- Bucket control group safety pins
- Hot and cold side of engine
- Articulation lock
- Hinged belly guards



## Engine

Engine Model	Cat C15 ACERT™	
Rated Power	1900/1800 rpm	
Gross Power – SAE J1995	321/333 kW	430/447 hp
Net Power – SAE J1349	290/302 kW	389/405 hp
Net Power – ISO 9249	288/300 kW	386/402 hp
Net Power – 80/1269/EEC	321/333 kW	430/447 hp
Bore	137.2 mm	5.4 in
Stroke	171.5 mm	6.8 in
Displacement	15.2 L	927.9 in <sup>3</sup>

- Power ratings apply at a rated speed of 1900/1800 rpm when tested under the reference conditions for the specified standard.
- Ratings based on SAE J1995 standard air conditions of 25° C (77° F) and 100 kPa (29.61 Hg) barometer. Power based on fuel having API gravity of 35 at 16° C (60° F) and an LHV of 42 780 kJ/kg (18,390 BTU/lb) when engine used at 30° C (86° F).
- No engine derating required up to 591 m (1,938 ft) altitude.
- Compliant with U.S. Environmental Protection Agency Tier 3 emissions standards.

## Operating Specifications

Nominal Payload Capacity	17 200 kg	37,926 lb
Gross Machine Operating Weight	67 409 kg	148,611 lb
Static Tipping Load Straight Ahead Lift Arms Horizontal	39 923 kg	88,015 lb
Static Tipping Load Full Turn Lift Arms Horizontal	34 069 kg	75,109 lb
Breakout Force (SAE)	27 346 kg	60,298 lb

## Weights

Empty	50 209 kg	110,692 lb
Front Axle	23 057 kg	50,832 lb
Rear Axle	27 152 kg	59,860 lb
Loaded	67 409 kg	148,611 lb
Front Axle	50 220 kg	110,716 lb
Rear Axle	17 189 kg	37,895 lb

## Transmission

Forward 1	5 km/h	3.1 mph
Forward 2	8.8 km/h	5.5 mph
Forward 3	15.2 km/h	9.4 mph
Forward 4	25.3 km/h	15.7 mph
Reverse 1	6.2 km/h	3.9 mph
Reverse 2	10.9 km/h	6.8 mph
Reverse 3	18.6 km/h	11.6 mph
Reverse 4	26.4 km/h	16.4 mph

## Hydraulic Cycle Time

Raise	9.2 Seconds
Dump	3.4 Seconds
Lower, empty, float down	3.1 Seconds
Total Cycle Time	15.7 Seconds

## Bucket Capacities

Bucket Capacity – Std.*	7.2 m <sup>3</sup>	9.4 yd <sup>3</sup>
Bucket Width (over cutting edge)	3154 mm	124.2 in
Bucket Capacity – Optional*	8.3 m <sup>3</sup>	10.9 yd <sup>3</sup>
Bucket Capacity – Optional*	8.9 m <sup>3</sup>	11.6 yd <sup>3</sup>

\* High penetration bucket versions also available.

## Turning Dimensions

Outside Clearance Radius**	7323 mm	288.3 in
Inner Clearance Radius**	3383 mm	133.2 in
Axle Oscillation	8°	
Articulation Angle	42.5°	

\*\* Clearance dimensions are for reference only.

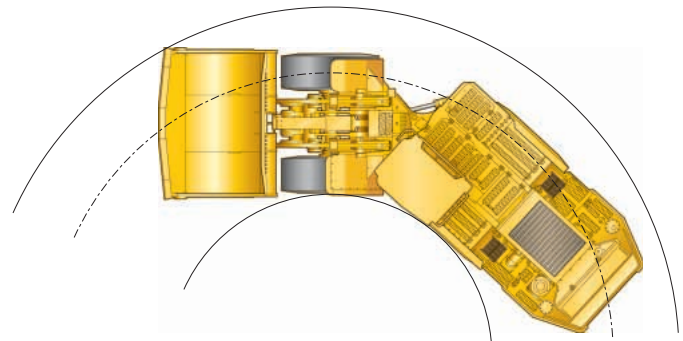

## Service Refill Capacities

Engine Crankcase	34 L	9 gal
Transmission	62 L	16.4 gal
Hydraulic Tank	140 L	37 gal
Cooling System	75 L	19.8 gal
Front Differential and Final Drives	119 L	31.4 gal
Rear Differential and Final Drives	127 L	33.5 gal
Front Differential and Final Drives (with Axle Oil Cooling System)	159 L	42 gal
Rear Differential and Final Drives (with Axle Oil Cooling System)	167 L	44.1 gal
Fuel Tank	854 L	225.6 gal
Secondary Fuel Tank (If Equipped)	571 L	150.8 gal

## Tires

Tire Size	29.5 × 29 34 PLY STMS
-----------	-----------------------

## Standards

Brakes	ISO3450, AS2958.1, CAN-CSA424.30-M90
Cab/FOPS	ISO3449, SAEJ231, AS2294.3, EN13627
Cab/ROPS	ISO3471, SAEJ1040, AS2294.2, EN13510

# Dimensions

All dimensions are approximate.

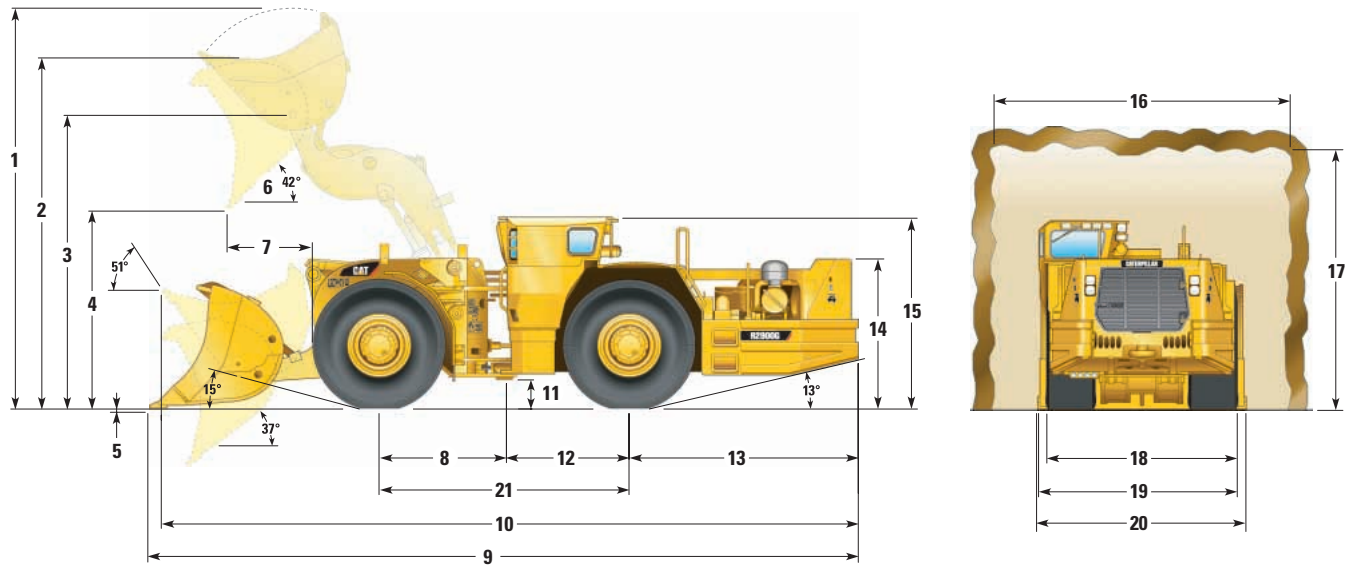

	249-4899 (Standard Bucket)*		249-4892*		249-4893*	
Bucket capacity	7.2 m <sup>3</sup>	(9.4 yd <sup>3</sup> )	8.3 m <sup>3</sup>	(10.9 yd <sup>3</sup> )	8.9 m <sup>3</sup>	(11.6 yd <sup>3</sup> )
Bucket width over cutting edge	3054 mm	(10 ft)	3154 mm	(10 ft 4 in)	3354 mm	(11 ft)
<b>1</b> Overall height – bucket raised	6179 mm	(20 ft 3 in)	6232 mm	(20 ft 6 in)	6232 mm	(20 ft 6 in)
<b>2</b> Maximum dump height	5427 mm	(17 ft 10 in)	5427 mm	(17 ft 10 in)	5427 mm	(17 ft 10 in)
<b>3</b> Bucket pin height at maximum lift	4539 mm	(14 ft 11 in)	4539 mm	(14 ft 11 in)	4539 mm	(14 ft 11 in)
<b>4</b> Dump clearance at maximum lift	2868 mm	(9 ft 5 in)	2735 mm	(9 ft)	2724 mm	(8 ft 11 in)
<b>5</b> Digging depth	52 mm	(2 in)	65 mm	(2.6 in)	65 mm	(2.6 in)
<b>6</b> Dump angle at maximum lift	42°		42°		42°	
<b>7</b> Reach	1656 mm	(5 ft 5 in)	1803 mm	(5 ft 11 in)	1817 mm	(6 ft)
<b>8</b> Centerline of front axle to centerline of hitch	1890 mm	(6 ft 2 in)	1890 mm	(6 ft 2 in)	1890 mm	(6 ft 2 in)
<b>9</b> Overall length (digging)	11 302 mm	(37 ft 1 in)	11 507 mm	(37 ft 9 in)	11 525 mm	(37 ft 10 in)
<b>10</b> Overall length (tramming)	10 949 mm	(35 ft 11 in)	11 073 mm	(36 ft 4 in)	11 083 mm	(36 ft 4 in)
<b>11</b> Ground clearance	465 mm	(1 ft 6 in)	465 mm	(1 ft 6 in)	465 mm	(1 ft 6 in)
<b>12</b> Centerline of back axle to centerline of hitch	1890 mm	(6 ft 2 in)	1890 mm	(6 ft 2 in)	1890 mm	(6 ft 2 in)
<b>13</b> Length – rear axle to bumper	3572 mm	(11 ft 9 in)	3572 mm	(11 ft 9 in)	3572 mm	(11 ft 9 in)
<b>14</b> Height to top of hood	2371 mm	(7 ft 9 in)	2371 mm	(7 ft 9 in)	2371 mm	(7 ft 9 in)
<b>15</b> Height to top of ROPS	2886 mm	(9 ft 6 in)	2886 mm	(9 ft 6 in)	2886 mm	(9 ft 6 in)
<b>16</b> Tunnel clearance width**	4500 mm	(14 ft 9 in)	4500 mm	(14 ft 9 in)	4500 mm	(14 ft 9 in)
<b>17</b> Tunnel clearance height**	4500 mm	(14 ft 9 in)	4500 mm	(14 ft 9 in)	4500 mm	(14 ft 9 in)
<b>18</b> Overall tire width	2898 mm	(9 ft 6 in)	2898 mm	(9 ft 6 in)	2898 mm	(9 ft 6 in)
<b>19</b> Overall width excluding bucket	3010 mm	(9 ft 10 in)	3010 mm	(9 ft 10 in)	3010 mm	(9 ft 10 in)
<b>20</b> Overall width including bucket	3176 mm	(10 ft 5 in)	3176 mm	(10 ft 5 in)	3176 mm	(10 ft 5 in)
<b>21</b> Wheelbase	3780 mm	(12 ft 5 in)	3780 mm	(12 ft 5 in)	3780 mm	(12 ft 5 in)

\*Dimensions shown with standard material bucket sizes. High penetration bucket versions also available.

\*\*Clearance dimensions are for reference only.



# Gradeability/Speed/Rimpull

To determine gradeability performance: Read from gross weight down to the percent of total resistance. Total resistance equals actual percent grade plus rolling resistance. As a general guide use 2% for rolling resistance in underground applications or refer to the Caterpillar Performance Handbook. From the

total resistance point, read horizontally to the curve with the highest obtainable gear, then down to maximum speed. Usable rimpull will depend upon traction available and weight on drive wheels.

----- Typical Field Empty Weight  
 ..... Loaded Weight

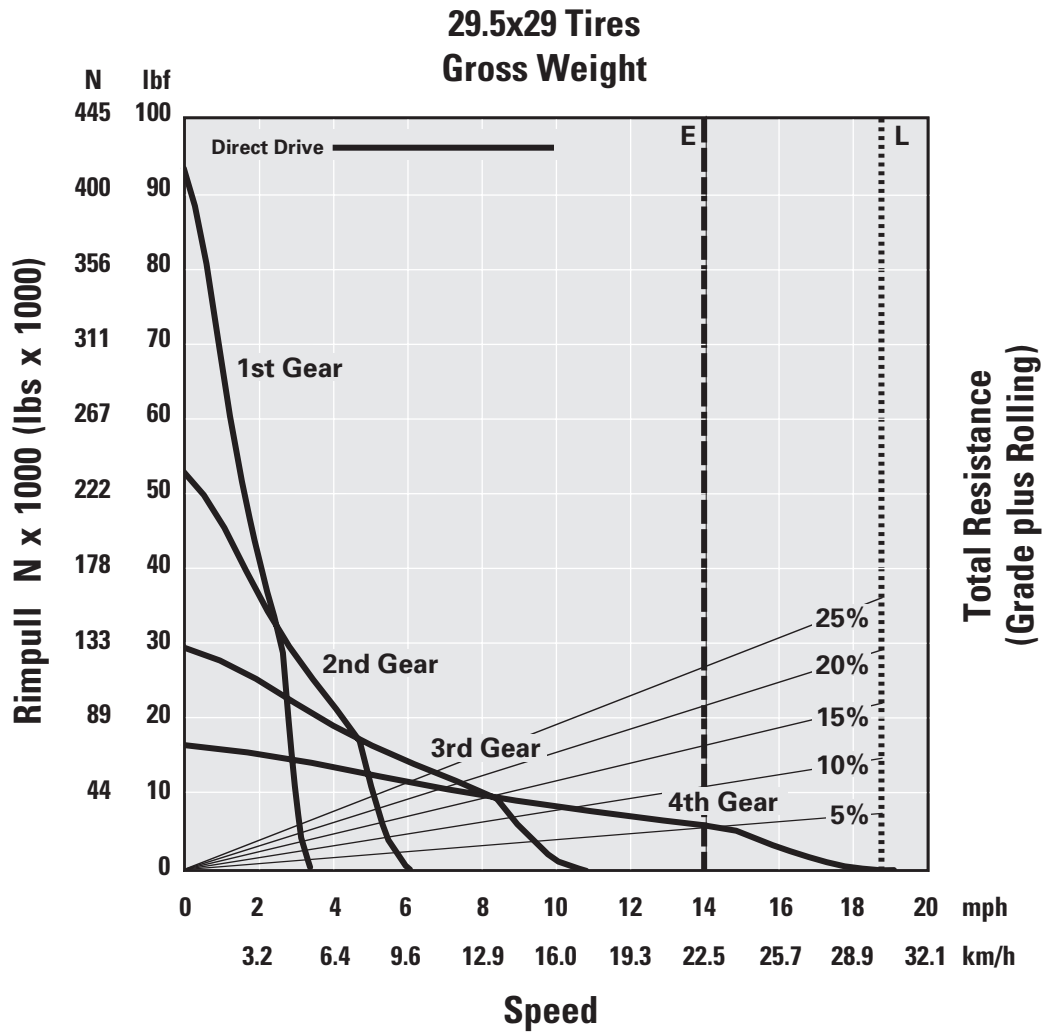

E - Empty 50 209 kg (110,711 lb)  
 L - Loaded 67 409 kg (148,637 lb)

## Standard Equipment

*Standard equipment may vary. Consult your Caterpillar dealer for details.*

### Electrical

- Alternator, 95-amp
- Battery Disconnect Switch, Ground Level
- Corrosive Protection Spray
- Diagnostic Connector
- Electric Starting, 24-volt
- Engine Shutdown Switch
- External Lighting System, Front, Rear
- Low Maintenance Batteries
- Reversing Alarm
- Starting And Charging System

### Operator Environment

- Caterpillar Electronic Monitoring System (CEMS)
- Electric Horns
- Gauges
  - Engine Coolant Temperature
  - Fuel Level
  - Hydraulic Oil
  - Speedometer
  - Tachometer
- Pilot Hydraulic Implement Controls, Single Joystick
- ROPS/FOPS Structure
- Suspension Seat With Retractable Seat Belt
- Wheel Steer

### Power Train

- Cat C15 ATAAC Diesel Engine with ACERT™ Technology, 6-Cylinder
- Long Life Coolant
- Full Hydraulic Enclosed Wet Multiple-Disc Brakes (SAFR™)
- Planetary Powershift Transmission with Automatic Shift Control, 4 Speed Forward/4 Speed Reverse
- Engine Air Intake Precleaner
- Torque Converter
- Transmission Neutralizer
- Fuel Priming Aid
- Crossflow radiator

### Other Standard Equipment

- Auto Park Brake
- Brake Axle Cooling
- Bucket Positioner, Return To Dig
- Catalytic Exhaust Purifier/Muffler Group
- Engine And Transmission Belly Guards
- Fenders, Front, Rear
- Firewall
- Hardox 450 Bucket Lip
- Interlock System Includes ABA
- Rear Frame Protection Wear Bars 100 × 50 mm (4 × 2 in)
- Semi Centralized Lubrication Points
- Swing Out Radiator Grill
- Tires, STMS (L5) 29.5 × 29 34-Ply

## Optional Equipment

*Optional equipment may vary. Consult your Caterpillar dealer for details.*

Alternative Tire Arrangements  
Automatic Lube System  
Auxiliary Start Receptacle  
Brake Light  
Brake Pressure Gauges  
Brake Release Arrangements  
Bucket Heel Shrouds  
Bucket Sacrificial Wear Strip Package  
Centralized Lube System, Manual  
Draw Bar Attachment, Bolt-on  
Electronic Access Module  
Fast Fill System  
    Coolant  
    Engine  
    Fuel  
    Hydraulic  
    Transmission  
Fire Extinguishers  
Fire Suppression System  
Front Light Protectors

Heater, Air Conditioning  
Oil Sample Adapters  
Operators Station  
    Air Conditioning  
    Pressurizer  
    Dome Light  
    Radio Ready  
Payload Control System (PCS)  
Remote Activated Fire System  
Remote Control Systems  
    Proportional  
    Retrieval attachment  
Reversible Steering, Wheel Steer  
Ride Control System  
Seat Covers  
Secondary Steering System  
Service Tools  
STIC™ Steering  
Tee Seat

# R2900G Underground Mining Loader

For more complete information on Cat products, dealer services,  
and industry solutions, visit us on the web at [www.cat.com](http://www.cat.com)

© 2007 Caterpillar  
All Rights Reserved  
Printed in U.S.A.

Materials and specifications are subject to change without notice.  
Featured machines in photos may include additional equipment.  
See your Caterpillar dealer for available options.

CAT, CATERPILLAR, their respective logos and "Caterpillar Yellow,"  
as well as corporate and product identity used herein, are  
trademarks of Caterpillar and may not be used without permission.

AEHQ5608-01 (8-07)

**CATERPILLAR**<sup>®</sup>